

Malaria Antigen (Pf/Pan) Detection Test (Pf HRP-II /Pan pLDH)

IMMUNOPAK

Last update: 02/2017

INTENDED USE

Malaria Pf/Pan Ag is a chromatographic immunoassay for the rapid, qualitative differential detection of Histidine Rich Protein II (HRP-II) antigen and Plasmodium lactate dehydrogenase (pLDH) in human whole blood. This kit is intended for the discriminational detection of Malaria Pf infection and other pan malaria (Non-Pf malaria) infections in human blood sample. This kit is for professional use and only for the initial screening test and reactive samples should be confirmed by a supplemental assay such as microscopic examination of thin blood smear.

INTRODUCTION

Malaria is a serious parasitic disease characterized by fever, chills and anemia and is caused by a parasite that is transmitted from one human to another by the bite of infected *Anopheles* mosquitoes. There are four kinds of malaria that can infect humans: *Plasmodium falciparum*, *P. vivax*, *P. ovale* and *P. malariae*. In humans, the parasites (called sporozoites) migrate to the liver where they mature and release another form, the merozoites. The disease now occurs in more than 90 countries worldwide, and it is estimated that there are over 500 million clinical cases and 2.7 million malaria-caused deaths per year. At present, malaria is diagnosed by looking for the parasites in a drop of blood. Blood will be put into a microscope slide and stained so that the parasites will be visible under a microscope.

PRINCIPLE

Malaria Pf/Pan Ag introduces 4 different monoclonal antibodies. It contains a membrane strip, which is pre-coated with two monoclonal antibodies as two separate lines across a test strip. One monoclonal antibody (test line Pf) is specific to Histidine-Rich Protein II (HRP II) of the *Plasmodium falciparum* species and the other line (test line Pan) is Pan specific to Lactate Dehydrogenase (pLDH) of the *Plasmodium* species (*Plasmodium falciparum*, *P. vivax*, *P. ovale* and *P. malariae*). The conjugate pad is dispensed with two monoclonal antibodies conjugated with colloidal gold, which are *P. falciparum* specific to HRP II and Pan Specific to pLDH. This rapid diagnostic system can be achievable to differentially diagnose *P.falciparum* and other species of malaria. Malaria antigens, HRP II (Histidine Rich Protein II) and LDH (lactate dehydrogenase) monoclonal antibody-coupled gold conjugate followed by reaction with anti-HRP II or anti-LDH monoclonal antibody in the test lines. When the blood sample is infected with malaria, a visible line appears in the test region on the membrane. To serve as a procedural control, an additional line of Goat anti-mouse IgG has been immobilized on the strip. If the test is performed correctly, this will result in the formation of pink-purple line on control line.

PRESENTATION

	25 Tests	50 Tests
Malaria Pf/Pan Antigen Test Cards	25 Cards	50 Cards
Assay Buffer	1 Bottle	2 Bottles
Sample Dropper (5µl)	25 Droppers	50 Droppers
Sterile Lancet	25 Nos.	50 Nos.
Alcohol Pad	25 Nos.	50 Nos.
Product insert		

STORAGE AND STABILITY

Malaria Pf/Pan Antigen test card should be stored at 4-40°C. The card may be stored at room temperature but not exceeding 40°C in the original sealed pouch. The shelf life or expiry of the card is printed on the pouch as well as on the carton label. The test kit should be kept away from direct sunlight, moisture and heat.

PRECAUTION

1. Read the product insert before carrying out the test and Instructions must be followed exactly to get accurate results.
2. The device is sensitive to humidity as well as to heat. So, it's very important to take off the device from the sealed pouch when used.
3. Do not use the kit after the expiration date.
4. For in vitro diagnostics use only.

5. Dispose all the samples and kits properly after test, in accordance with GLP.

SPECIMEN COLLECTION AND STORAGE

1. The test should be performed with freshly collected human blood from the fingertip or by vein puncture using sample tube containing anticoagulant.
2. For the short term storage, please keep the specimen at 2-8°C, for the long term storage; please keep the sample below - 20°C.

TEST PROCEDURE:

Note: - The test device should be use immediately (within 2 minutes) after removal from the pouch.

1. Clean the fingertip with the alcohol swab and let it dry completely. Prick the fingertip with a single use lancet.
2. Collect 5 µl of blood using the capillary dropper (upto indicated marking).
3. Load the 5 µl of blood into the sample well "S" of the test device.
4. Add 2-3 drops (60-90 µl) of assay buffer (Diluent) into the assay buffer well, "A" of the test device.

Note: - After 5 minutes of adding specimen and buffer, you may add one more drop of assay buffer for better background clearance.

5. Immediately start the stop watch and read the results at the end of 20 minutes.
6. Refer to the following pictures for analysis of the test result.

IMPORTANT NOTE:

Results should not be read beyond 30 minutes. Reading too late may give false results.

INTERPRETATION OF RESULT

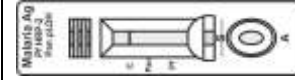
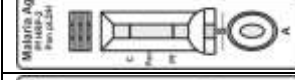
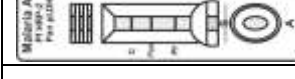
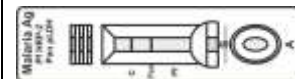
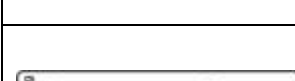
	NEGATIVE for malaria: Only one pink-purple line appears in the control area marked 'C'.
	P. falciparum Positive: Two lines, control line "C" and test line "Pf" or three lines (Pf, Pan & C) appears in the test window. The blood sample is infected by <i>P. Falciparum</i> .
	Pan Positive: Control line "C" and test line "Pan" appears in the test window. The blood sample is infected by <i>P. vivax (in usual)</i> or <i>P.malariae / P.ovale (in rare)</i> .
	Mixed Infection: Along with the control line "C", the test line "Pf" and the test line "Pan" appears in the test window. The sample is infected with <i>P.falciparum</i> and <i>P.vivax</i> (or <i>P. malariae</i> , <i>P. ovale</i>)
	INVALID RESULT: If control line "C" does not appear, the test is may be invalid. In this case, please repeat the test following the test procedure exactly.

PERFORMANCE CHARACTERISTICS

In an in-house study, a panel of 250 samples whose results were earlier confirmed with microscopy were tested with Malaria (Pf/Pan) Ag card. The results obtained are as follows:

Sample	Total No. of samples tested	Malaria (pf/pan) Ag test		Sensitivity (%)	Specificity (%)
		Positive	Negative		
P. falciparum positive	18	18	0	100	-
P. vivax positive	27	27	0	100	-
Malaria Negative	205	0	205	-	100

Malaria Antigen (Pf/Pan) Detection Test (Pf HRP-II /Pan pLDH)

IMMUNOPAK

SENSITIVITY

The sensitivity of Malaria (Pf/Pan) antigen test is compared to microscopic examination with more than 100 parasites per μl of blood.

LIMITATIONS

1. The test procedure, precautions and interpretation of results for this test must be followed when testing.
2. Malaria Pf/Pan Ag test is designed for primary screening test of malaria infection.
3. The results of test are to be interpreted within the epidemiological, clinical and therapeutic context. When it seems indicated, the parasitological techniques of reference should be considered (microscopic examination of the thick smear and thin blood films).
4. Anti-coagulants such as heparin, EDTA, and citrate do not affect the test result.
5. Do not mix reagent of different lots.
6. This kit can provide fast and easy way to get a result, but do not completely exclude the possibility of false positive or false negative result caused by various factors. So, refer to the result of this kit, please make a final decision with clinical manifestation, other test results, and doctor's view, collectively.

REFERENCES

1. World Health Organization-Geneva (2000) new perspectives malaria diagnosis.
2. Perlmann, P. and Troye-Blomberg, M.2002. Malaria parasites and disease. Malaria Immunology.
3. Malcolm, J.G., et al, 2002.Genome sequence of the human malaria parasite Plasmodium falciparum. Nature.419:498-511
4. Warhurst,D.C, D.C, D.C., and J.E. Williams.1996. Laboratory diagnosis of malaria. J.Clin. Patol.49:533-538.

TEST PROCEDURE:

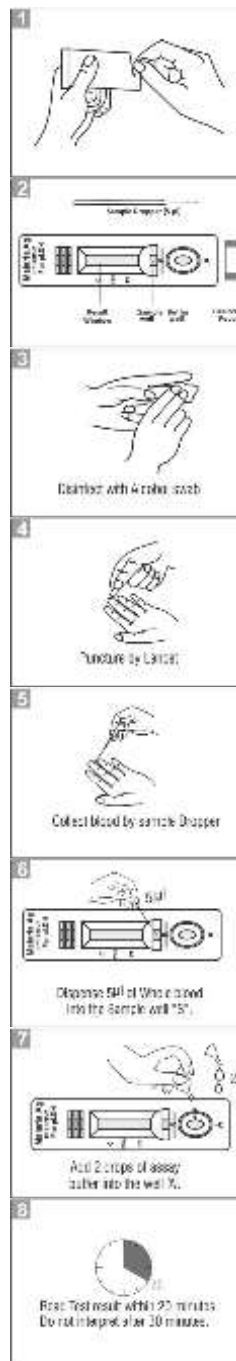

Open pouch at cut mark and remove all content, the device, sample dropper and desiccant pouch. Once opened, the device must be used immediately.

Component details are shown in picture.

Clean the finger to be pricked, with an alcohol swab. Allow to dry.

Take a lancet & prick the finger with the pointed end of the lancet.

Collect the blood sample up to indicated marking by sample dropper.

Load the collected blood (5 μl) in the sample well 'S' of the test device.

Hold the assay buffer vial vertically straight & add exactly 2 drops in to the well 'A'.

Start the stop watch and read the test results at the end of 20 minutes.

